

# Application of universal software defined PXI platform for the performance evaluation of FM-DCSK communications system

Tamás Krébesz

Dept. of Measurement and Inf. Sys.  
Budapest Univ. of Technology and  
Economics, Budapest, Hungary  
Email: krebesz@mit.bme.hu

Géza Kolumbán

Faculty of Information Technology  
Pázmány Péter Catholic University  
Budapest, Hungary  
Email: kolumban@itk.ppke.hu

Francis C. M. Lau and Chi K. Tse

Dept. of Electronic and Information Eng.  
The Hong Kong Polytechnic University  
Hung Hom, Kowloon, Hong Kong SAR  
Email: {encmlau, encktse}@polyu.edu.hk

**Abstract**—A specific method for the application of a universal software defined wireless platform is presented to determine system performance of communications system based on real field tests. On the platform every application can be implemented: the transmitter and the receiver establishing a wireless link, the communications channel and the algorithm to determine system performance. Implementation is done in software that offers flexible, efficient and cheap solution for performance testing. Every physical RF analog signals generated or processed in software can be recovered on the PXI hardware platform used in our tests. Since the analog RF output and input of the transceiver are available, real field tests can be performed or even the system performance can be evaluated in a real operating network. Using the PXI platform, based on real field tests the evaluation of system performance of a 2.4-GHz ISM band wireless communication system with FM-DCSK modulation is presented here. A systematic method for the validation of system implemented on the PXI HW is provided.

## I. INTRODUCTION

Transition from simulations to field test measurements is a very time consuming and expensive process if the conventional approach is used where (i) a chipset implementing the new idea is developed first and then (ii) the performance of the new system is evaluated against the real application environment. The alternative solution is to check the performance of the new idea only by computer simulation. The latter approach has a huge risk because the system performance cannot be evaluated in real field tests. Any error done in modelling or simulation results in a completely wrong conclusion.

In our approach (i) everything is or can be implemented in software but (ii) all physical RF analog signals can be recovered and processed. Property (i) offers the required level of flexibility, the cheap and fast implementation, while Property (ii) makes the system evaluation possible in a real environment where the physical RF analog signals are measured. Such a system, referred to as universal Software Defined (SD) wireless platform, can be connected even to an already existing and operating communications network.

This contribution shows the development, validation and application such a platform via the implementation of FM-DCSK communications systems. To achieve the theoretically attainable minimum sampling rate, the concept of complex

envelopes are used in the SD wireless platform and every SW algorithm is run in baseband (BB).

## II. RADIO SYSTEM TO BE IMPLEMENTED AND TESTED

In a Frequency-Modulated Differential Chaos Shift Keying (FM-DCSK) system [1], an alternative to spread spectrum systems, a chaotic waveform is used to carry the information. Chaotic waveforms are noise-like wideband signals having no frequency, phase or amplitude. Consequently, radio chipsets developed to build conventional wireless communications systems cannot be applied, the use of SD approach and PXI-based universal HW platform is the only way to (i) implement an FM-DCSK transceiver, (ii) carry out the necessary field tests, (iii) measure its BER performance and (iv) prove the feasibility of the FM-DCSK system.

### A. Operation principle and baseband model of FM-DCSK system

In a binary transmitted reference (TR) system two signals, called chips, are used to transmit one bit information. The first chip serves as a reference, while the second one carries the information.

The structure of an FM-DCSK TR signal is shown in Fig. 1, where  $g(t)$  denotes the chaotic wavelet,  $T_b$  is the bit duration. The chip duration equals  $T_b/2$ . Antipodal modulation scheme is used where the information bearing chip is equal to the delayed reference chip for bit “1,” and to the inverted and delayed reference chip for bit “0.”

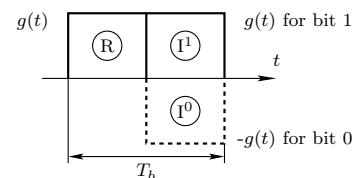

Fig. 1. Structure of FM-DCSK TR signal.

BB model of FM-DCSK modulator and demodulator has been developed in [2]. Figure 2 shows the BB equivalent of FM-DCSK modulator where  $m(t)$  denotes the chaotic wavelet,  $b_i$  is the digital bit stream to be transmitted,  $s_I(t)$  and  $s_Q(t)$

are the I/Q components, respectively, of the complex envelope of transmitted RF signal  $s(t)$ . Note, the constituting blocks of modulator, such as FM modulator and DCSK modulator, are identified in the figure.

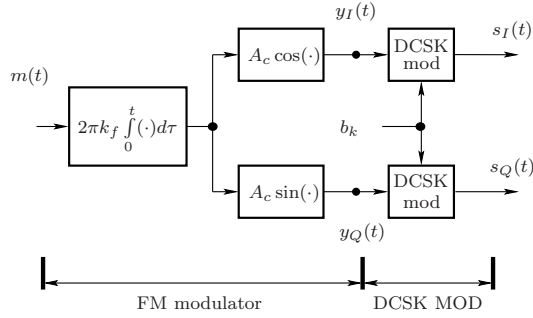

Fig. 2. BB equivalent of FM-DCSK modulator.

BB equivalent of FM-DCSK demodulator is given in Fig. 3 where  $r_I(t)$  and  $r_Q(t)$  are the I/Q components, respectively, of the complex envelope of received noisy RF signal  $r(t)$ . The in-phase component of the complex impulse response of channel filter is denoted by  $h_I(t)$  while the quadrature component equals zero since a zero-phase filter is used as a channel filter. For more details and the steps of derivation of BB equivalents refer to [2].

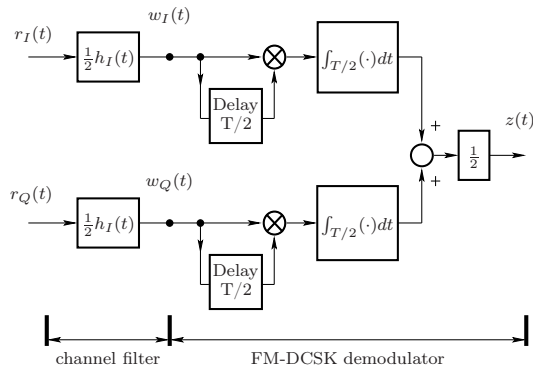

Fig. 3. BB equivalent of FM-DCSK demodulator.

The application of BB equivalents is essential since digital signal processing in the PXI system relies on the complex envelopes.

### B. Channel model

The BB equivalent of radio channels can be defined by either (i) their *complex impulse response* provided by a standard committee [3] or (ii) a *tapped delay line model*. For simplicity, the tapped delay line model elaborated by the PCS Joint Technical Committee and published in [4] is considered here for office, residential and commercial environments. These channel models are integrated into the BB signal processing algorithm at the transmitter side. The BB model of a multipath propagation channel can be formulated as

$$\tilde{r}(t) = \sum_{i=1}^N \alpha_i \tilde{s}(t - \tau_i) \exp(-j2\pi f_C \tau_i) + \tilde{n}(t)$$

where  $\tilde{s}(t) = s_I(t) + js_Q(t)$  and  $\tilde{r}(t) = r_I(t) + jr_Q(t)$  are the complex envelopes of the transmitted and received signals, whose I/Q components can be identified in Figs. 2 and 3, respectively.  $N$  is the number of the propagation paths, the  $i$ -th path is characterized by its delay  $\tau_i$  and attenuation  $\alpha_i$ ,  $f_C$  is the RF center frequency. The RF AWGN channel noise, characterized by its BB equivalent  $n_I(t)$  and  $n_Q(t)$ , is also generated in BB. Note,  $\tilde{n}(t) = n_I(t) + jn_Q(t)$ .

During field test measurements not channel models but antennas and a real channel environment have been used. The application of channel model in the PXI system is explained in Sec. IV.

## III. DESCRIPTION OF THE PXI-BASED SD WIRELESS PLATFORM

The PXI-based SD wireless platform performs all the waveform-specific signal processing steps, such as modulation and demodulation, in BB on the host PC in SW while all the general purpose operations requiring high-speed data processing, such as interpolation and decimation, digital-to-analog and analog-to-digital conversion and RF up- and downconversion are carried out by the PXI modules. Photo of the PXI-based SD wireless platform is shown in Fig. 4 where the PXI-based HW platform can be seen in the upper left corner.

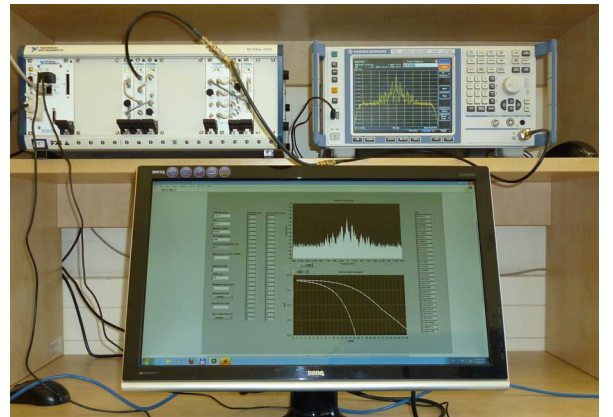

Fig. 4. Picture of the PXI-based universal SD wireless platform.

### A. PXI-based HW platform

Peripheral component interconnect eXtensions for Instrumentation (PXI) environment offers a standardized PC-hosted professional modular platform for high performance measurement and automation systems [6]. Every PXI platform has three constituting components, the (i) host PC or (embedded) system controller, (ii) PXI peripheral modules and (iii) chassis that houses the controller and rack-mounted modules. The chassis offers advanced timing and synchronization capabilities. The block diagram of the PXI-based platform is shown in Fig. 5, where all components are identified. The PXI peripheral modules constitute a vector signal generator (VSG) as transmitter (Tx) and a RF signal analyzer (RFSA) as receiver (Rx). For field test measurements the separation distance,  $R$ , of Tx and Rx antennas was always far field, i.e.,  $R > 2D^2/\lambda$ , where  $D$  is the aperture of the antenna used, and  $\lambda$  is the wavelength of the RF carrier.

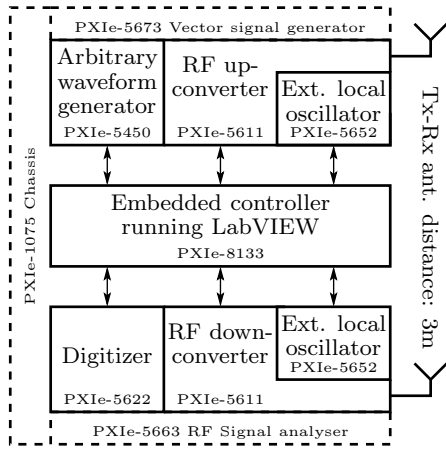

Fig. 5. Block diagram of the PXI-based HW platform

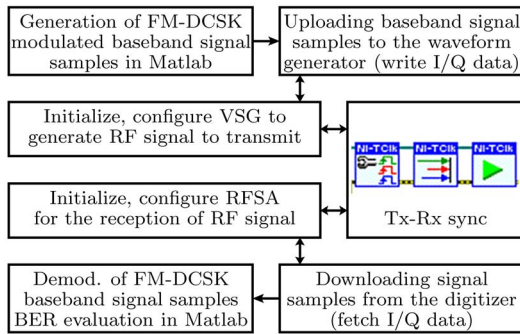

Fig. 6. Block diagram of the SW components of the wireless platform

### B. Software platform for accessing PXI devices

Efficient software platform to provide access to PXI system is LabVIEW. LabVIEW integrates all the components needed for (i) controlling the PXI system, (ii) the implementation of SD applications and (iii) the evaluation of system performance. The functional block diagram of the SW for the PXI-based wireless platform is shown in Fig. 6. The samples of the FM-DCSK modulated signal, generated in the BB, are uploaded to the memory of arbitrary waveform generator (AWG), shown on the top right in Fig. 5. The parameters for the generation and reception of RF signal are passed to the RF upconverter and downconverter modules, respectively, by the SW. The digitized samples of the received signal are fetched and the demodulation is done in the baseband by SW.

The PXI architecture shares timing and synchronization signals, therefore, tight and precise synchronization can be achieved among PXI modules. The skew can be even less than 20 ps. To achieve this tight synchronization careful configuration of PXI modules is required that includes three basic steps: (i) configuration of the PXI system to use homogeneous triggers, (ii) synchronization of the analyzer and generator sections and (iii) initiation the signal generation and acquisition at the same time. These steps can be identified in the right middle of Fig. 6 implemented in LabVIEW.

LabVIEW offers a user interface, referred to as “*Front Panel*,” where all the signals can be visualized and all the parameters can be entered. The Front Panel of PXI-based SD

wireless platform developed to measure the performance of the FM-DCSK radio link is shown in Fig. 7. System parameters, BB spectrum of received signal, BER curves, recovered bit sequences are visualized on the Front Panel.

### C. Integration of Matlab-based FM-DCSK into PXI platform

Modulation and demodulation of FM-DCSK, generation of channel noise, multipath propagation are all implemented in BB and in MATLAB by integrating them into LabVIEW during the PXI-based implementation of FM-DCSK system. Matlab code can be integrated into LabVIEW via “*MATLAB script*” window that runs the MATLAB SW engine in the background and provides a SW interface to pass or share BB signals between the two platforms.

### D. Operation principle of the bit recovery procedure

When the BB samples of the received waveform are available, the timing information has to be recovered first. To do it a 0101... antipodal training sequence is placed before each transmitted packet. Then, the recovery of bits, i.e., the demodulation is performed. In the last step the frames carrying the useful information are identified using a start frame delimiter defined by IEEE802.11. BER evaluation is based on the comparison of the *a priori* known transmitted bit sequence and the recovered bit sequence.

## IV. APPLICATION OF PXI-BASED WIRELESS PLATFORM FOR PERFORMANCE EVALUATION

The PXI-based Tx unit generates the required modulated waveform by transforming the I/Q components, i.e. the complex envelope of BB signal into the RF domain. By exploiting the SD approach even channel conditions can be implemented in BB and they can be added in SW to the complex envelope of modulated signal to be transmitted. The PXI Tx unit is driven by this composite complex envelope, consequently, its output includes both the modulated signal and the channel effects. This capability is one of the main features of SD PXI approach that makes the use of expensive channel sounder and/or RF noise generator unnecessary. During the development of the system this capability has been exploited for the validation of the channel model and the testbed itself.

For the evaluation of FM-DCSK system performance, the PXI-based SD wireless platform, shown in Fig. 4, has been set up in our laboratory. On the top left the PXI-chassis, while on the top right a stand-alone spectrum analyzer (SA) are shown. During the performance evaluation the spectra are always checked by the stand-alone SA beside the BB spectra of the transmitted FM-DCSK signal. A qualitative comparison can be made between BB and RF spectra by comparing the *BB Power Spectrum* of Fig. 7 and RF spectrum of the same signal shown in Fig. 8. The two spectra are identical in terms of their shape and dynamic-range.

### A. BER performance in AWGN and multipath channels

First, the implementation loss has to be determined in an AWGN channel. In Fig. 9 solid curve shows the system performance in AWGN channel calculated from [7]. Dashed curve is fitted to the results of cable connected measurements

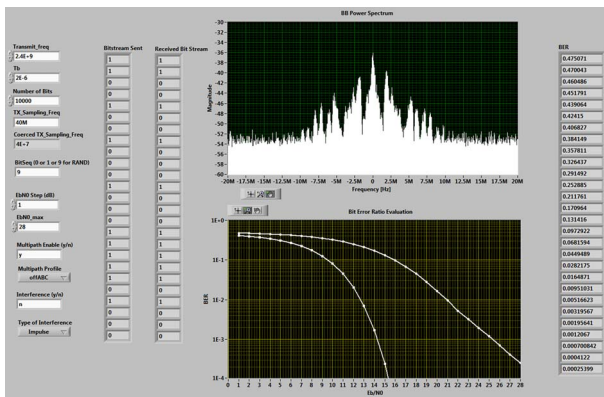

Fig. 7. User interface of the implemented FM-DCSK radio link implemented in office environment.

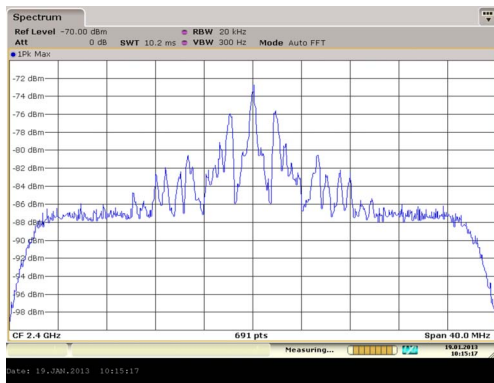

Fig. 8. Measured spectrum of FM-DCSK in office environment.

indicated by '+' marks for AWGN channel on the PXI-based wireless platform. Inspecting the solid and dashed curves in Fig. 9 it can be concluded that an inevitable implementation loss is always present. The implementation loss is about 0.7 dB, on average, which is introduced by (i) the noise of the PXI external local oscillators used for both the transmitter and receiver, (ii) the noise contribution of the PXI up- and downconverter units and (iii) the quantization error of PXI waveform generator and digitizer, each appear in Fig. 5.

To perform real field tests the RF cable has been removed and 2.4GHz antennas have been installed with 3m separation. Dotted curve in Fig. 9 shows the simulated BER of FM-DCSK in indoor multipath environment, while the results of the field tests are shown by '\*' marks to which a BER curve shown in dash-dot has been fitted. The BER measured in indoor residential environment using the PXI platform lags behind the results of simulations by  $\sim 1.7$  dB at  $\text{BER}=10^{-4}$ . It means that (i) the applied channel model is validated for our system based on real field tests and (ii) the implementation of FM-DCSK is feasible on the PXI SD wireless platform.

## V. CONCLUSIONS

The theory and practice of software defined wireless platform developed for performance evaluation over various channel conditions have been discussed. Moreover, a systematic method for the validation of the implemented system has been proposed.

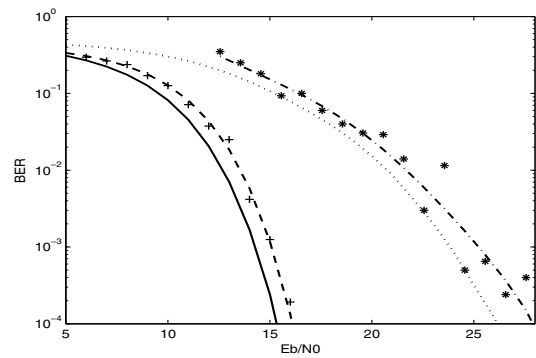

Fig. 9. Measured performance of FM-DCSK system with bit duration  $2\mu s$  in real channels. Solid and dashed curves show the theoretical BER in AWGN channel and simulated BER in indoor residential multipath channel. Dashed and dash-dotted curves are based on real measurement results marked by '+' for AWGN, and '\*' for indoor residential multipath channels, respectively.

The PXI wireless platform implements every applications in BB. The software defined approach assures flexibility and cheap implementation, while the PXI-based hardware establishes the transformation between the data sequences processed in baseband and the physical RF analog signals.

To show the effectiveness of the PXI-based SD wireless platform proposed here, the system performance of a 2.4-GHz FM-DCSK radio transceiver has been evaluated in AWGN and noisy multipath channels based on field test measurements. The measurement results have been compared against the theoretical and simulation results.

## ACKNOWLEDGMENT

The research has been sponsored by the Hungarian Scientific Research Fund (OTKA) under Grant number T-084045, Hungarian National Development Agency under Grant number TÁMOP 4.2.1/B-11/2/KMR-2011-0002 and by the Hungarian-French Intergovernmental S&T Cooperation Program. The HW and SW platforms used for the implementation and measurements have been donated by National Instruments.

## REFERENCES

- [1] G. Kolumbán, M. P. Kennedy, and G. Kis, "Performance improvement of chaotic communications systems," in *Proc. ECCTD'97*, Budapest, Hungary, August 30–September 3 1997, pp. 284–289.
- [2] G. Kolumbán, "Performance evaluation of chaotic communications systems: Determination of low-pass equivalent model," invited tutorial at Nonlinear Dynamics of Electronic Systems, in *Proc. NDES'98*, Budapest, Hungary, July 16–18 1998, pp. 41–51.
- [3] A. F. Molisch et al., *IEEE 802.15.4a Channel Model – Final Report*, IEEE802.15.4a Channel Modeling Subgroup, Online: <<http://www.ieee802.org/15/pub/04/>>, 2004.
- [4] K. Pahlavan and A. H. Levesque, *Wireless Information Networks*. New York: Wiley, 1995.
- [5] G. Kolumbán, T. Krébesz, and F. C. M. Lau, "Theory and application of software defined electronics: Design concepts for the next generation of telecommunications and measurement systems," *IEEE Circuits and Systems Magazine*, vol. 12, no. 2, pp. 8–34, Second Quarter 2012.
- [6] *PXI Hardware Specification, Revision 2.2*, PCI eXtensions for Instrumentation, PXI Systems Alliance, 2004.
- [7] G. Kolumbán, "Theoretical noise performance of correlator-based chaotic communications schemes," *IEEE Trans. Circuits and Syst. I*, vol. 47, no. 12, pp. 1692–1701, December 2000.